



Weights and Dimensions

External Dimensions:

Length: 20'12" 6400mm
 Width: 7'2" 2105mm
 Height: 9'8" 2935mm

Approx. Weight:

Unladen Weight: 1985kg*
 Axle 1: 1500kg
 Axle 2: 1500kg
 Axle 3: 1500kg
 Gross Weight: 3500kg

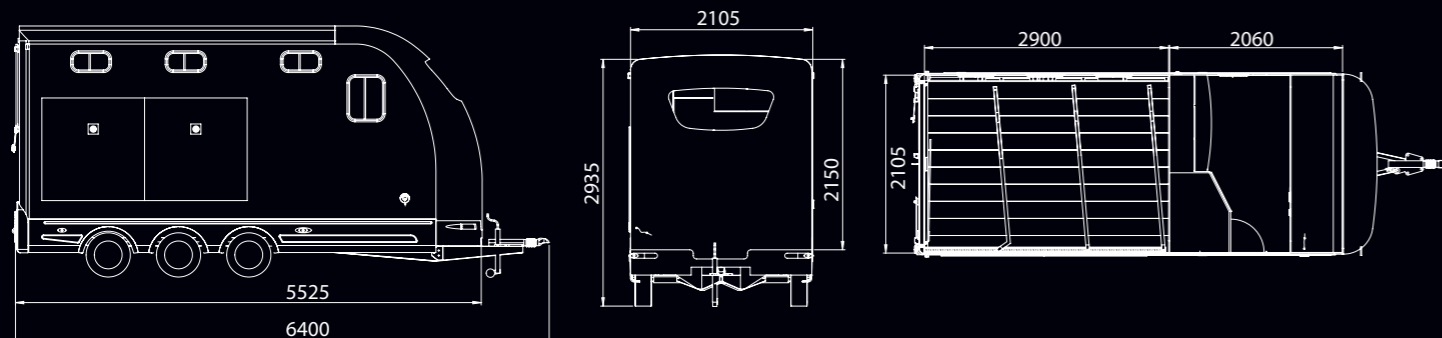

*Plan view shows internal dimensions



Multi-Treka



Equi-Trek Multi-Treka

The tri-axle Multi-Treka can carry up to three ponies/horses (depending on size and weight) complete with a full luxurious living area providing overnight accommodation for two people.

The wide body allows horses to turn easily, whilst the herringbone travel is preferred by some horses.



Horse Area

- Self-Contained Horse Area
- Skylight Roof Vent
- Composite High Impact Kick Boards
- Composite Panels
- Groom's Door Between Horse Area and Living Area
- Light and Spacious Interior
- One Interior Light
- Slip Resistant Rubber Ramp
- Strong Aluminium Plank Floor
- Three Horse and Haynet Tie Rings
- Three Saddle and Bridle Racks
- White Easy Clean Safety Loading Doors
- Adjustable Padded Partitions with Integral Head Dividers



Main Body

- Aerodynamic Fibreglass Mould
- Galvanised Steel Chassis
- Lockable Coupling
- Independent Suspension
- Six Fully Braked Wheels
- Built in ISO9001 Factory
- Large Front Locker
- Three External Tie Rings



Tack/Changing Area

- Large Interior Light with Additional Spot Lights
- Dining Layout as Standard (Other Option Available)
- Easy-Clean Cushion Flooring
- Fitted Curtains
- Kitchen Unit
- Sink with Tap
- Living Area Door
- Living Door Window
- Mirror
- Toilet Area
- Leisure Battery
- 70 Litre Under Floor Water Tank
- Seating Converts to Double Bed

